

ADDO L96

Pullert / Bollard / Poller / Pollare

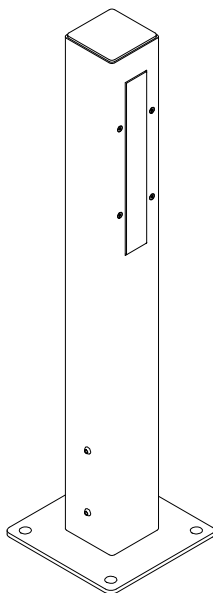

Monteringsvejledning / Mounting instructions /
Installationsanleitung / Installationsinstruktioner

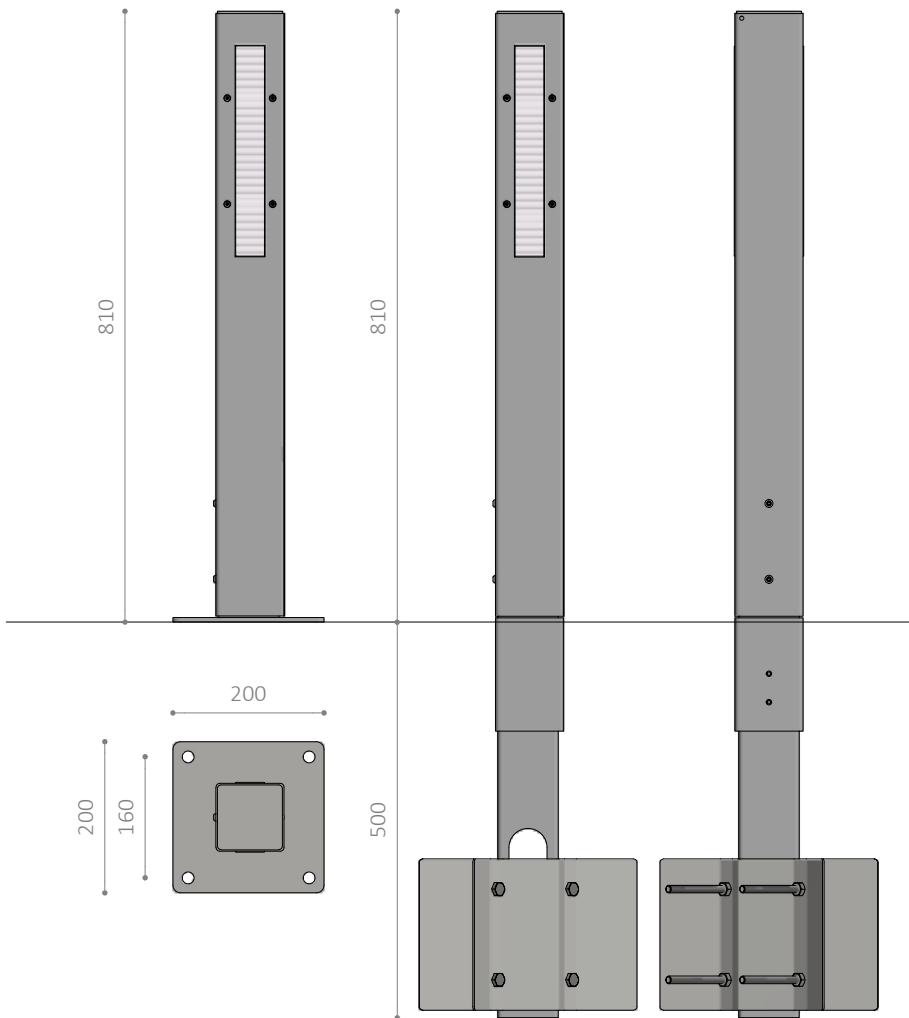

Værktøj / Tool / Werkzeug / Verktyg:



4 mm

1



4 mm

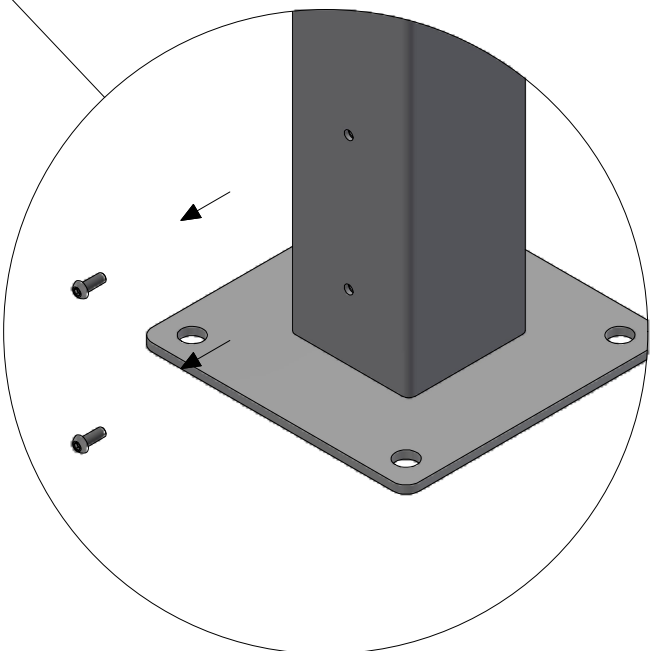
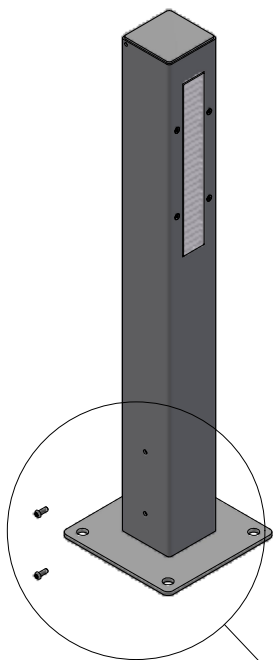

2

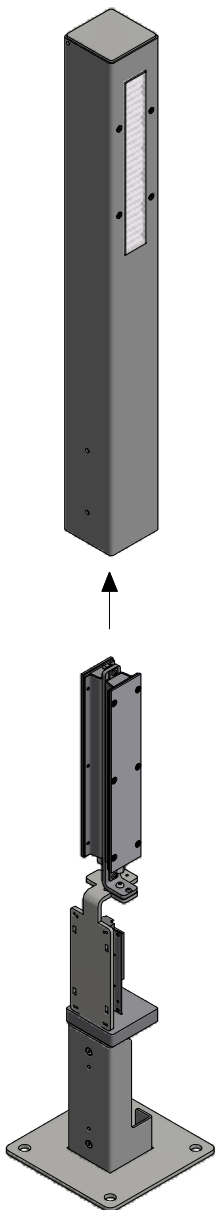

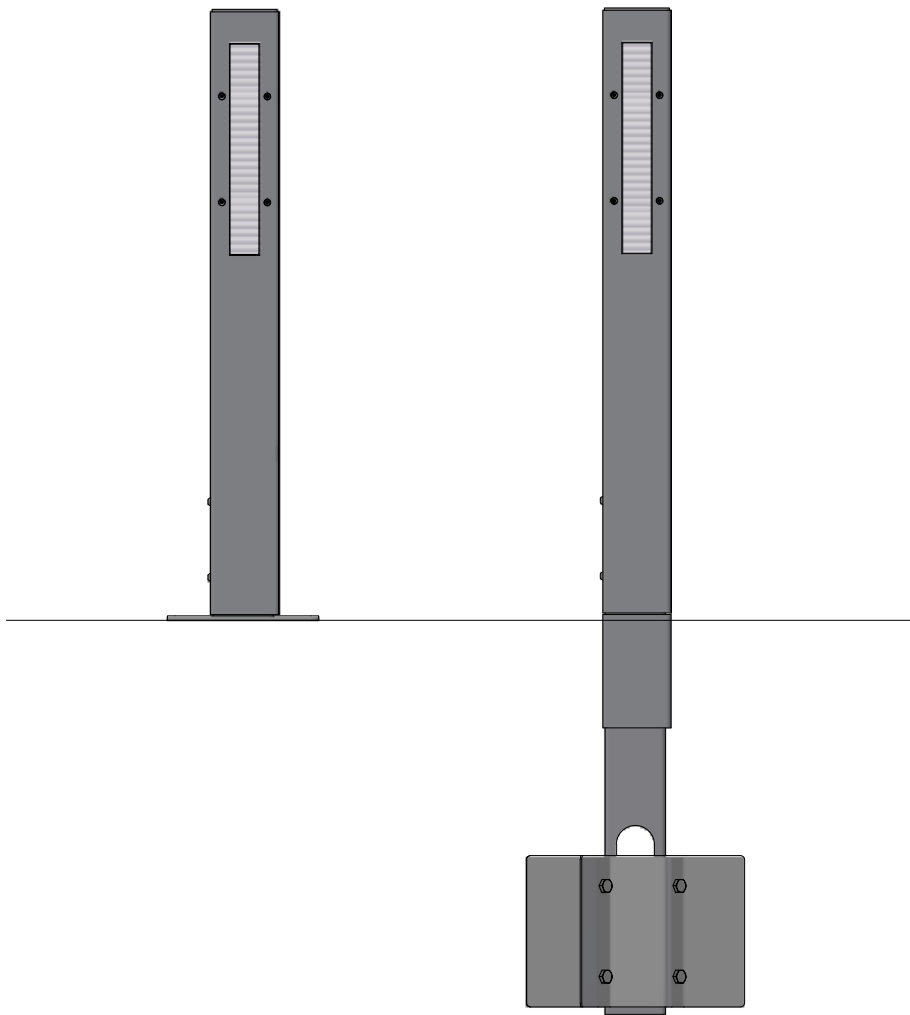

3-A

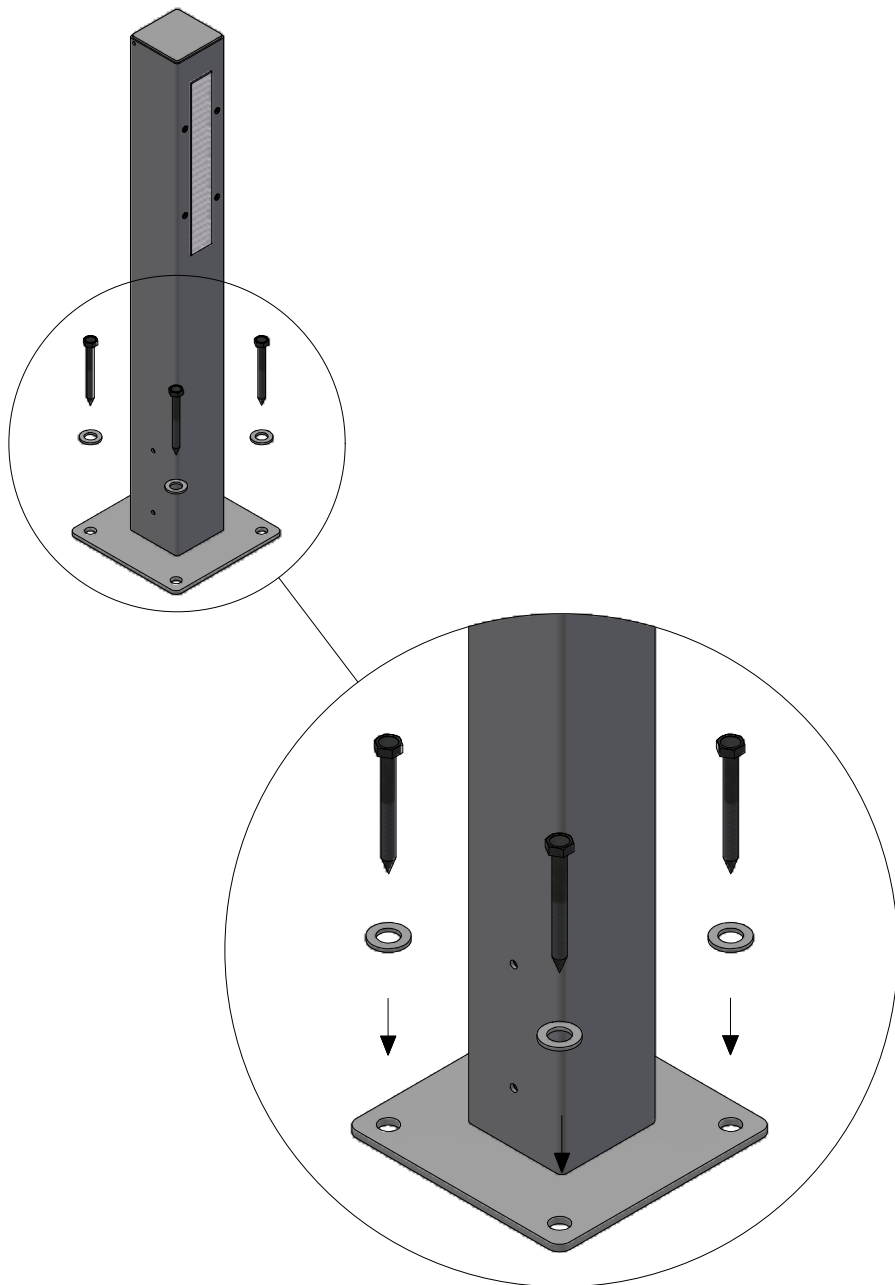

3-B

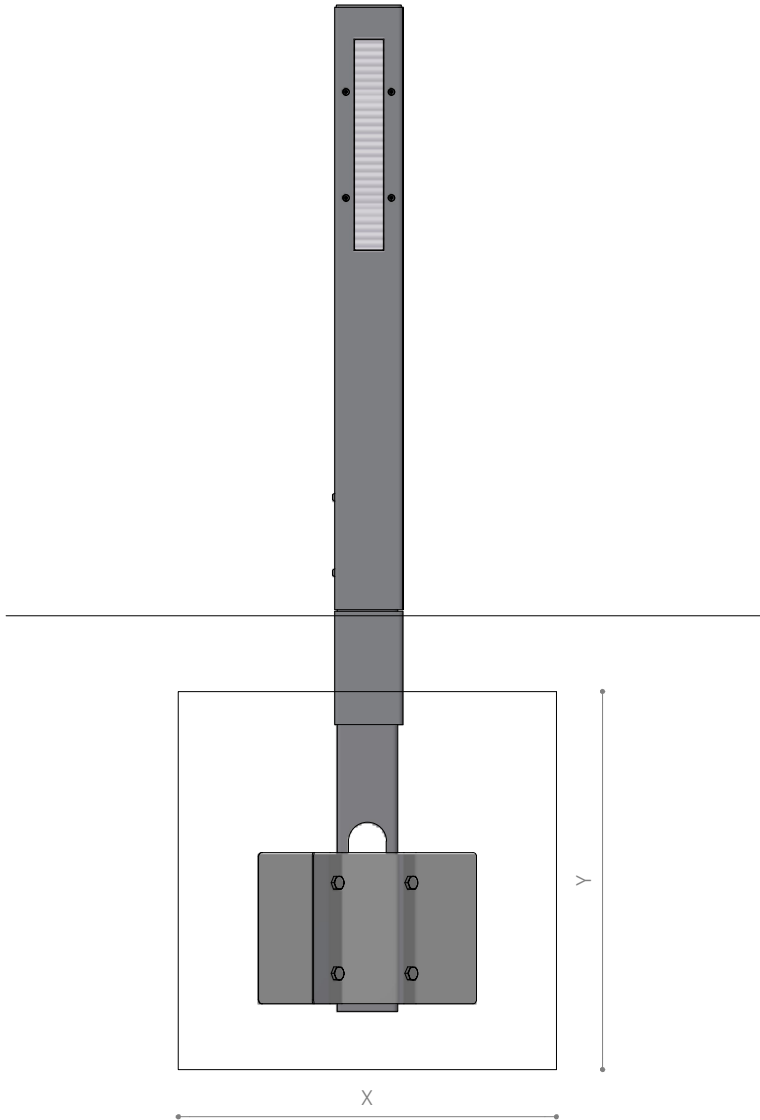

4

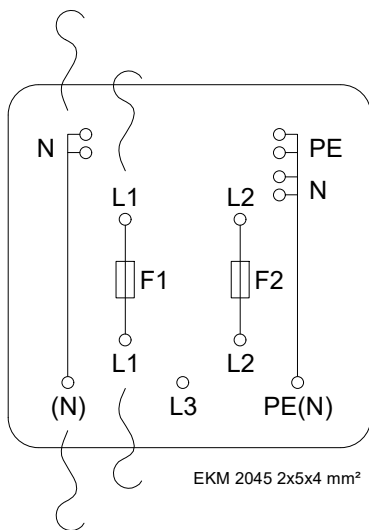
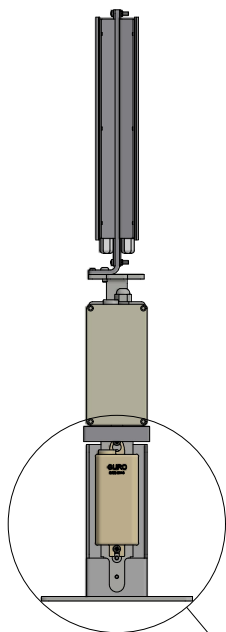

Isolationsklasse II / Insulation class II /
Schutzklasse II / Isolationsklass II

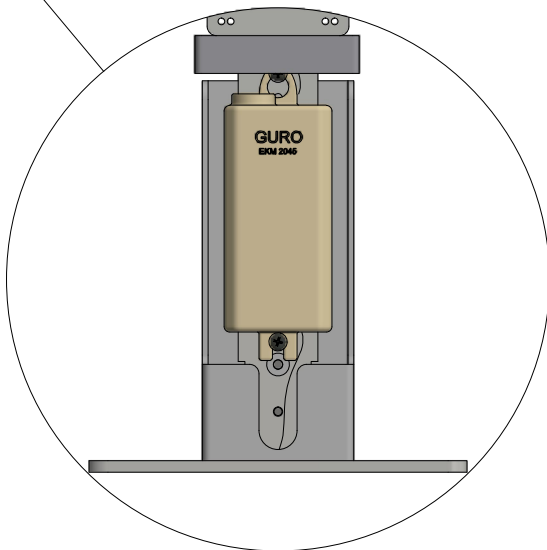

5

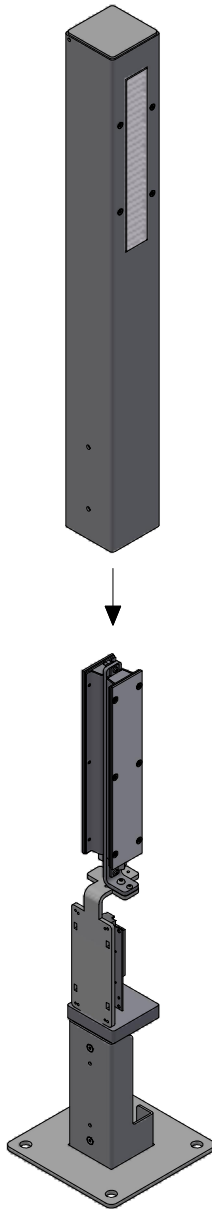

6



4 mm

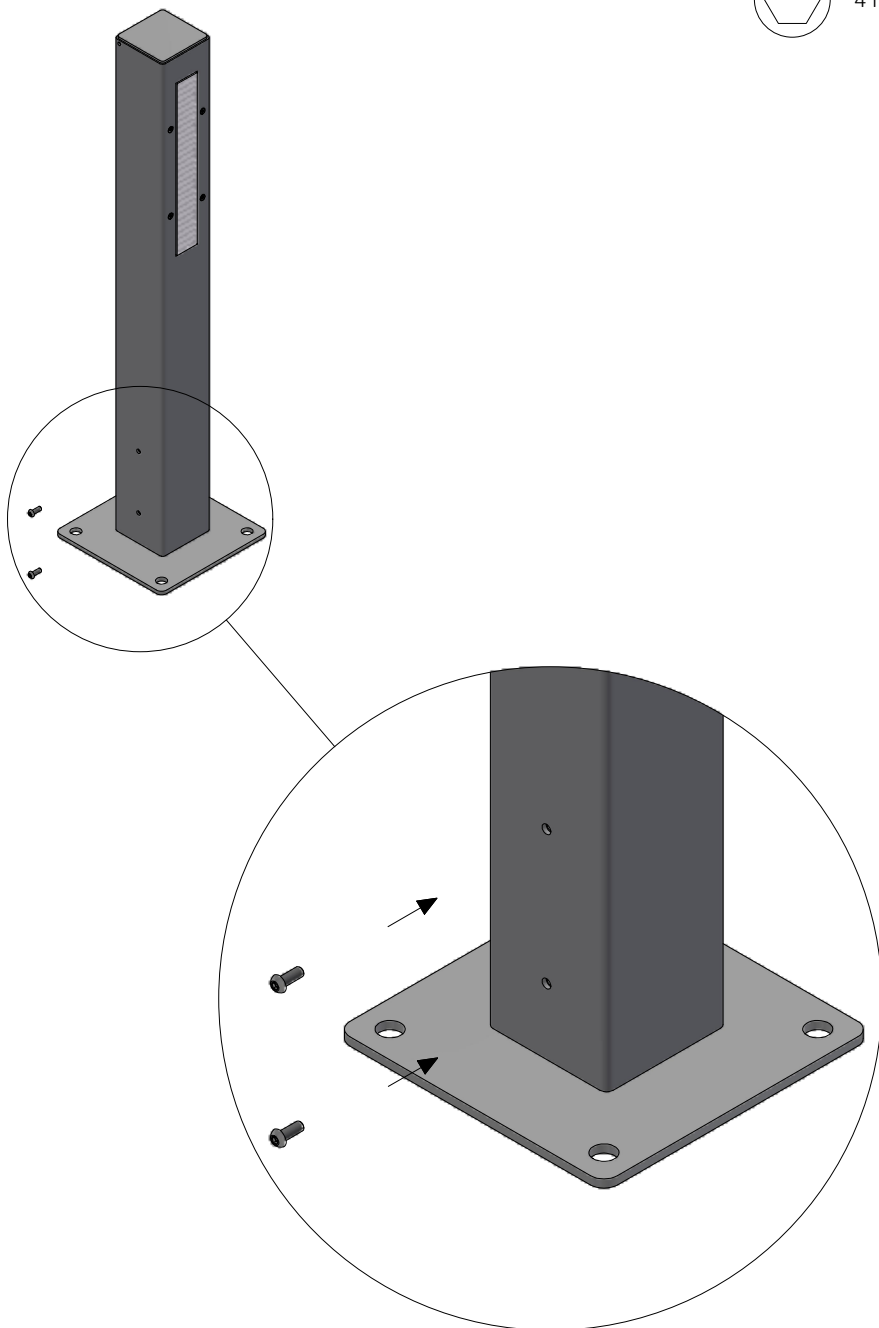



LED



1 lysåbning - 7W/830 eller 7W/840 50 Khrs.

2 lysåbninger - 14W/830 eller 14W/840 50 Khrs.



Isolationsklasse II / Insulation class II / Schutzklasse II / Isolationsklass II



IP54

IK

IK10



13 kg



Se vedligeholdelses vejledning / See maintenance instructions /
Siehe Wartungsanweisungen / Se underhålsinstruktioner



Montering/udskiftning må kun udføres af producenten eller aut. el-installatør /
Installation/replacement must only be carried out by the manufacturer or by
an electrician / Die Installation/der Austausch darf nur vom Hersteller oder von
einem Elektriker durchgeführt werden / Installation / utbyte får endast utföras
av tillverkaren eller av en behörig elektriker

Lampas